

I. INTRODUCTION

Item No. : 0442

Age : 8+

Product Contents:

R.E.V.™ AIR Drone x 1
R.E.V.™ AIR Car x 1
USB Charging Cable x 1
Rechargeable Battery x 1
Prop Guards x 4
Prop Guard Screws x 4
Quick Start Guide x 1
User Manual x 1

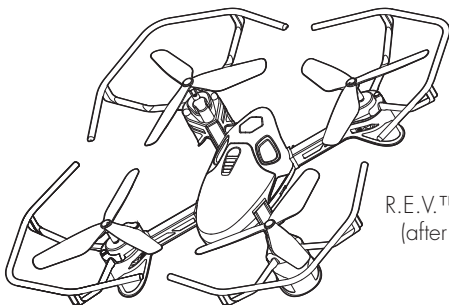

R.E.V.™ AIR Drone
(after assembly)

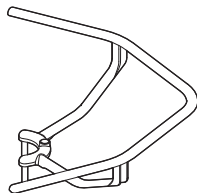

Prop Guards x 4



Prop Guard Screws x 4

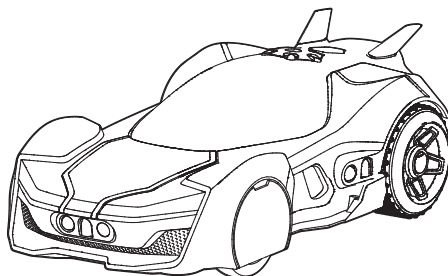

R.E.V.™ AIR Car

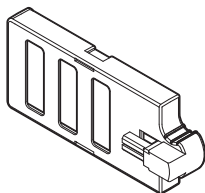

Rechargeable Battery



USB Charging Cable

Please note the following when operating the R.E.V.™ AIR Drone or R.E.V.™ AIR Car:

- Do not immerse the R.E.V.™ AIR Drone, R.E.V.™ AIR Car, or any of its parts or accessories in water or any other form of liquid.
- Do not drop, throw, or kick the R.E.V.™ AIR Drone, R.E.V.™ AIR Car, or its accessories as this may damage mechanical functions.
- Do not leave the R.E.V.™ AIR Drone or R.E.V.™ AIR Car unattended near edges from which it could fall.

2. BATTERY INFORMATION

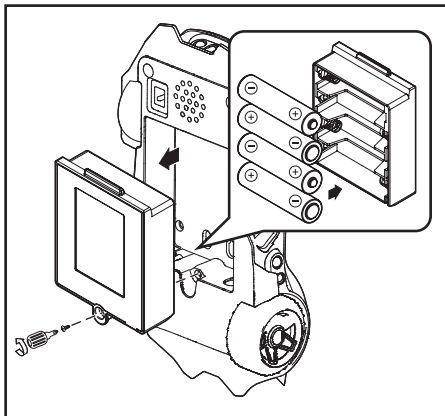

4 x "AA" Alkaline Batteries (not included)

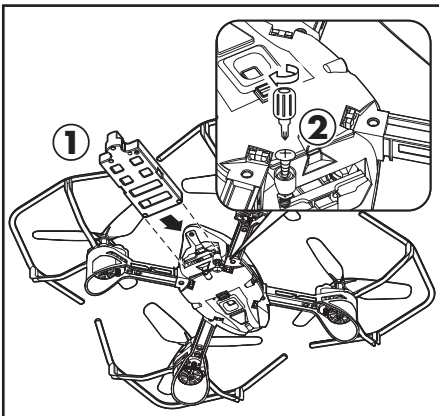

Rechargeable Battery (included)

R.E.V.™ AIR Car and R.E.V.™ Air Drone Battery Diagram/Installation

Installing or changing batteries in R.E.V.™ AIR Car:

1. Lay the R.E.V.™ AIR Car down so that the battery compartment faces upwards. The R.E.V.™ AIR Car requires 4 x "AA" size alkaline batteries (not included).
2. Using a Phillips screwdriver (not included) remove the screw on the battery compartment cover.
3. Remove any existing batteries and insert new batteries according to the diagram. Ensure that the positive and negative polarities match the illustrations inside the battery compartment.
4. Replace the battery compartment cover and tighten screw using the screwdriver. Do not over-tighten.

IMPORTANT BATTERY INFORMATION: (R.E.V.™ AIR Car)

- Use only fresh batteries of the required size and recommended type.
- Do not mix old and new batteries, different types of batteries [standard (Carbon-Zinc), Alkaline or rechargeable] or rechargeable batteries of different capacities.
- Remove rechargeable batteries from the toy before recharging them.
- Rechargeable batteries are only to be charged under adult supervision.
- Please respect the correct polarity, (+) and (-).
- Do not try to recharge non-rechargeable batteries.
- Do not dispose of batteries into fire.
- Replace all batteries of the same type/brand at the same time.
- The supply terminals are not to be short-circuited.
- Remove exhausted batteries from the toy.
- Batteries should be replaced by adults.
- Batteries should be recycled or disposed of as per state and local guidelines.

LOW BATTERY INDICATORS:

R.E.V.™ AIR Drone - When the battery grows weak, the R.E.V.™ AIR Drone will start flashing red, land automatically, and then will no longer fly. You can also see current battery levels via the R.E.V.™ AIR App. When this happens, recharge the R.E.V.™ AIR Drone as indicated in the R.E.V.™ AIR Drone Rechargeable Battery Instruction Sheet.

R.E.V.™ AIR Car - When the batteries grow weak, the R.E.V.™ AIR Car will begin to move slower than normal. When the batteries are nearly depleted, it will make a low battery indication sound and then power off. When this occurs, power OFF and replace all batteries. You can also see current battery levels via the R.E.V.™ App.

3. APP COMPATIBILITY

Apple® iOS devices:

Works with iPhone®, iPad® & iPod touch® devices running iOS 9 or later*.

*Devices must also support Bluetooth® Smart (also known as Bluetooth® Low Energy).

Android™ devices:

Works with most Bluetooth® Smart Ready (also known as Bluetooth® Low Energy) devices running Android™ 4.4.4 (KitKat) or later*.

*The easiest way to test compatibility before purchasing the product is to attempt to download and run the R.E.V.™ App. If your device is not compatible, Google Play™ will not allow you to see, download, or install the app.

4. DOWNLOADING THE APP



For Apple® Devices:

Go to the App StoreSM and search for the WowWee "R.E.V." App. Then, click download.

For Android™ Devices:

Go to the Google Play™ Store or Amazon Appstore™ and search for R.E.V.™ App. Then, click download.

5. CONNECTING TO R.E.V.™ AIR DRONE AND R.E.V.™ AIR CAR WITH YOUR DEVICE

To connect R.E.V.™ AIR Drone and R.E.V.™ AIR Car with your device:

1. Turn the R.E.V.™ AIR Drone and R.E.V.™ AIR Car as instructed in the Quick Start Guide.
2. Open the R.E.V.™ App on your device.
3. Follow the on-screen instructions.

Q & A

Q: Is my tablet or phone compatible with R.E.V.™?

A: R.E.V.™ devices can be controlled using our free apps available for compatible smart devices featuring Bluetooth® Smart technology. These apps are available on iTunes® or the Google Play™ store.
iOS devices: All iPhone®, iPod® and iPad® devices (excluding iPad® 2) which run iOS 9 or later are compatible.

Android™ devices: The app is compatible with most Bluetooth® Smart Ready (BLE) phones and tablets running Android™ 4.4.4 or later. The easiest way to test compatibility before purchasing the product is to attempt to download the R.E.V.™ App. If your device is not compatible, Google Play™ will not allow you to see, download or install the app. If the app can download, install, and run correctly on your device, we expect full compatibility.

Q: I cannot access Google Play™ on my Android™ device, how can I download the application?

A: Try downloading the application on the Amazon AppStore™. All WowWee® applications are officially provided on the Amazon™ store for users who cannot use Google Play™.

Q: When I try to download the R.E.V.™ app on my Android™ phone, it says it's incompatible with my device.

A: R.E.V.™ only works with devices which are Bluetooth® Smart Ready and running compatible operating systems.

Generally our toys are expected to be compatible with any Android™ phone or tablet that is Bluetooth® Smart Ready (also known as Bluetooth® Low Energy) and running Android™ 4.4.4 or later.

The easiest way to test R.E.V.™ app compatibility on your Android device is to attempt to download the R.E.V.™ App. If your device is not compatible, Google Play™ will not allow you to see, download, or install the app. If the app can

download, install, and run correctly on your device, we expect full compatibility.

Q: My R.E.V.™ device won't show up in the app when I try to connect.

A: Make sure your R.E.V.™ device has fresh/fully charged batteries and is turned on, then close the app and switch Bluetooth® on/off in your device settings. If you're still having problems, try restarting your device completely.

Q: My R.E.V.™ device disconnects often or R.E.V.™ AIR Drone automatically lands after taking off.

A: This is most likely caused by Bluetooth® interference. Ensure that there are no other Bluetooth® devices connected or switched on (especially audio devices), as these can cause interference which can cause issues. If you're still having problems try turning your device's WiFi off to reduce interference.

Q: The R.E.V.™ AIR Drone takes off, but then the motors stop running and it falls down.

A: Most likely the battery is flat; try recharging or swapping the Rechargeable Battery.

Q: Can I use R.E.V.™ without a compatible smart device?

A: No. R.E.V.™ can only be used together with a compatible smart device.

Q: The R.E.V.™ AIR Drone has trouble tracking or seems to get confused about where to fly.

A: Ensure that the Pod is in an open clear space indoors with line of sight to the toy. The R.E.V.™ AIR Drone will not function correctly in crowded spaces or outdoors.

For more in-depth FAQ, please refer to www.wowwee.com/rev

Manufactured and distributed by © 2015 WowWee Group Limited. Product names, designations, and logos are trademarks or registered trademarks of WowWee Group Limited. All rights reserved.

Customer Service Website: www.wowweezone.com

We recommend that you retain our address for future reference.

Product and colors may vary.

Packaging printed in China.

WARNING! This product is not suitable for children under 3 years because of small parts - choking hazard.

Apple, the Apple logo, iPhone, iPad, iPad mini, iPad Air, and iPod touch are trademarks of Apple Inc., registered in the U.S. and other countries. App Store is a service mark of Apple Inc., registered in the U.S. and other countries.

Android and Google Play are trademarks of Google Inc.

Amazon and Amazon Appstore are trademarks of Amazon.com, Inc.

MADE IN CHINA

CAUTION

Changes or modifications not expressly approved by the party responsible for compliance could void the user's authority to operate the equipment.

NOTE

This equipment has been tested and found to comply with the limits for a class B digital device, pursuant to part 15 of the FCC rules. These limits are designed to provide reasonable protection against harmful interference in a residential installation. This equipment generates, uses and can radiate radio frequency energy and, if not installed and used in accordance with the instructions, may cause harmful interference to radio communications.

However, there is no guarantee that interference will not occur in a particular installation. If this equipment does cause harmful interference to radio or television reception, which can be determined by turning the equipment off and on, the user is encouraged to try and correct the interference by one or more of the following measures:

- Reorient or relocate the receiving antenna
- Increase the separation between the equipment and receiver
- Connect the equipment into an outlet on a circuit different from that to which the receiver is connected
- Consult the dealer or experienced radio/TV technician for help

This Device complies with Part 15 of the FCC Rules. Operation is subject to the following two conditions:

- (1) This device may not cause harmful interference, and
- (2) This device must accept any interference received, including interference that may cause undesired operation.

This device complies with Industry Canada Licence-exempt RSS-210. Operation is subject to the following two conditions:

- (1) This device may not cause interference, and
- (2) This device must accept any interference, including interference that may cause undesired operation of the device.

For these purposes, the party responsible is:

WowWee USA Inc.
7855 Fay Avenue, Suite 310
La Jolla CA, USA 92037
1-800-310-3033

For more in-depth instructions, please refer to www.wowwee.com/rev

For warranty information, please visit <http://www.wowwee.com/information/warranty>

WARNING! This equipment may experience difficulty and/or memory loss when subjected to any electrostatic discharge, radio frequency interference, or sudden power surge/interruption. The user is encouraged to reset the equipment should any of these occur.



WowWee Group Limited WowWee Canada Inc.
Energy Plaza, 301A-3700 Saint Patrick Street
92 Granville Road Suite 206
T.S.T. East, Hong Kong Montreal, QC, H4E 1A2, Canada

